

One-Bit Delta Sigma D/A Conversion

Part II: Implementation

Randy Yates

<mailto:randy.yates@sonyericsson.com>

July 28, 2004

Contents

1	Hardware Platform	3
2	Converter Parameters	4
3	Implementation Features	5

1 Hardware Platform

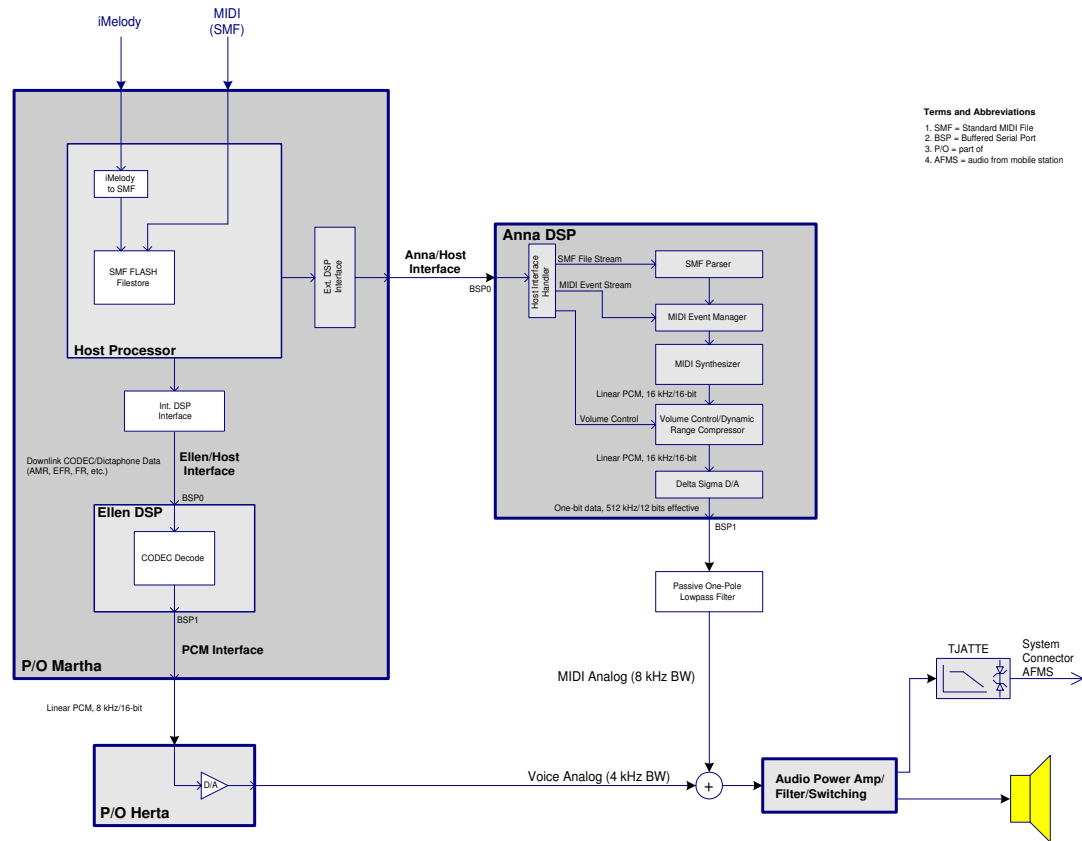

Figure 1: DSP-Based Polyphonic Ringtone Implementation

2 Converter Parameters

Baseband Sample Rate: 16 kHz typical, 8 kHz and 32 kHz available

Oversampling Ratio: $32\times$

Oversampled Sample Rate: 512 kHz, 256 kHz, and 1024 kHz, respectively

Interpolating Filter: 256-tap FIR

Modulator: Second-Order, with Psychoacoustic Noise-Shaping

Effective Number of Bits: ≈ 11 bits (from Figure 4] and D/A converter definition)

3 Implementation Features

- Polyphase filtering utilized in the interpolating filter
- Hard limiter as part of the interpolating filter
- A second-order modulator was used with modulator zeros placed at 4 kHz for psychoacoustic noise-shaping
- Composite electrical/acoustical output filtering via Helmholtz resonator

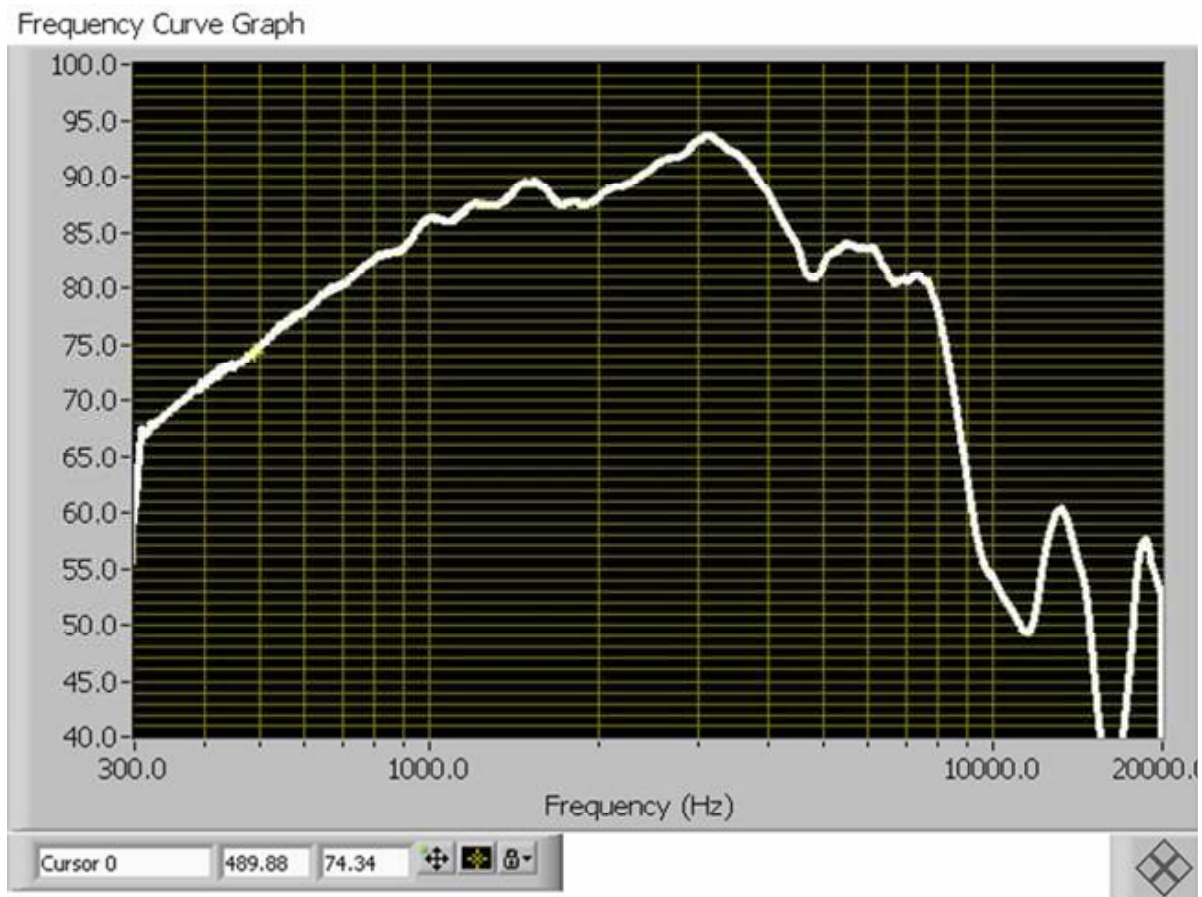

Figure 2: Acoustic Filtering

Integration issues:

- Intermodulation distortion in output amplifier
- Full-scale distortion

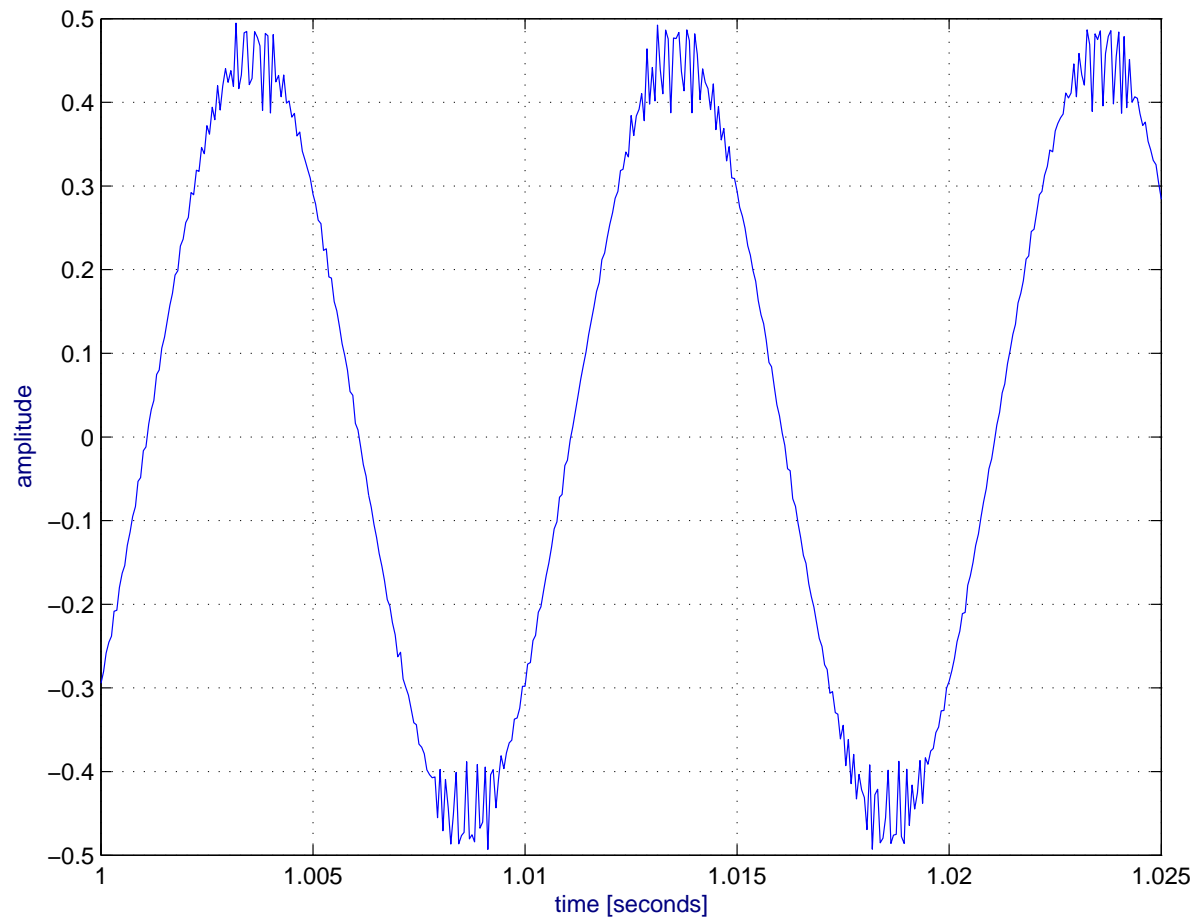

Figure 3: Distortion in Full-Scale Sine Wave

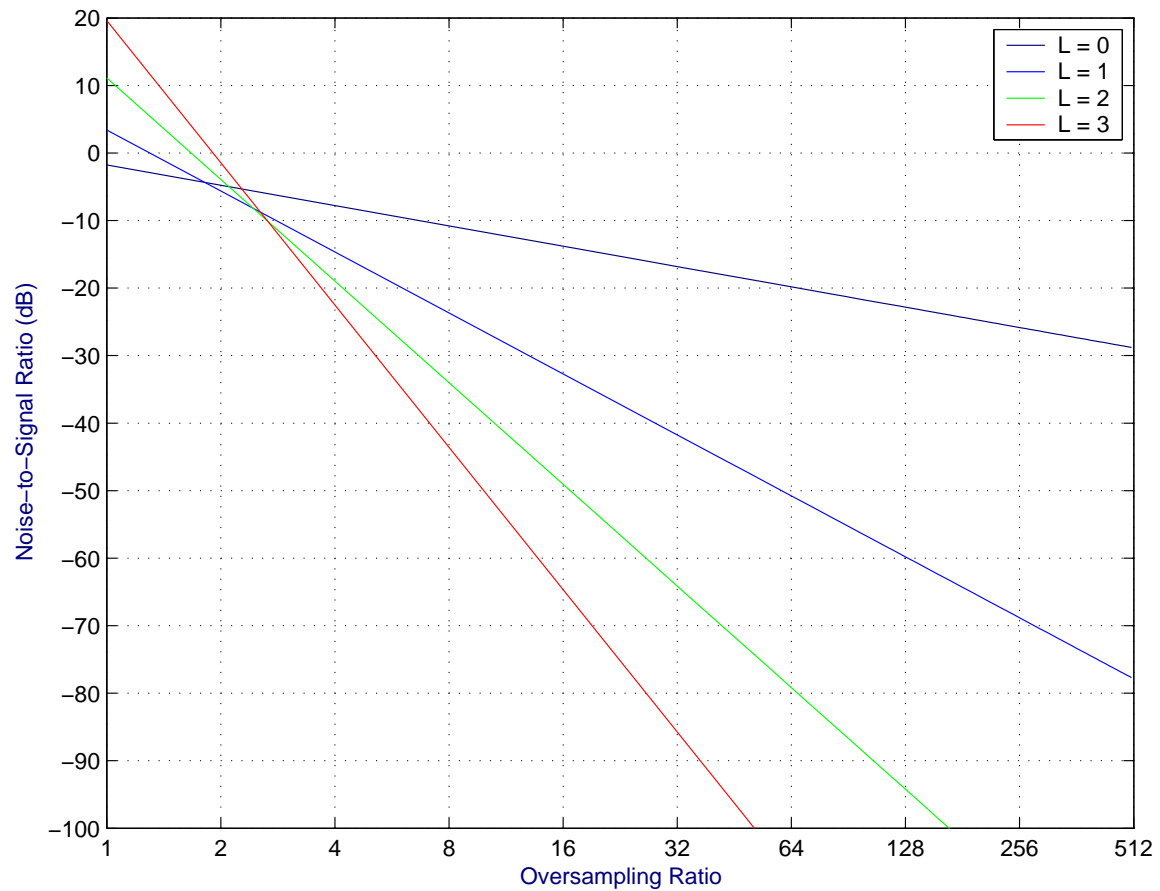

Figure 4: Ratio of In-Band Quantization Noise Power To Signal Power versus Oversampling Ratio and Modulator Order L